

## Terminal Unit and Zone Valve Actuators

MODEL	CONTROL SIGNAL	POWER SUPPLY	MAX. STROKE
MVT203	3-point - ON/OFF	230 V AC	16 mm
MVT403		24 V AC	
MVT503	Proportional	24 V AC	
MVT203S	3-point - ON/OFF	230 V AC	9 mm
MVT403S		24 V AC	
MVT503S	Proportional	24 V AC	



### APPLICATION AND USE

MVT actuator can be used with valves push/pull (using auto stroke calibration) or with valves with spring return using fixed stroke to control hot /cool water flow rate in two/four pipes terminal units, zone and solar plants, small reheating and dehumidification coils.

### TECHNICAL CHARACTERISTICS

DESCRIPTION	MVT
Power supply	24 V AC $\pm 10\%$ (MVT403/403S and MVT503/503S)
	230 V AC $\pm 10\%$ (MVT203/203S)
Consumption	2,2 VA/2,2 W (MVT403/403S)
	3,6 VA/3 W (MVT503/503S)
	16,2 VA/1,1 W (MVT203/203S)
Frequency	50/60 Hz
Stroke timing (50 Hz)	30s : VSX..PB 2,5mm stroke
	55s : VSXT..PB 5 mm stroke
	60s : V.XT, VSB.T/VMB.T, VSB.T./VMB.T. 5,5mm stroke
	100s : 2TGA..B 8,5mm stroke
	130s : 2-3TGB.B 11,5mm stroke
Speed	11,5s/mm at 50 Hz - 9,4s/mm at 60 Hz
Force	300N (UNI9497: 1989)
Operation temp	-5°C to 55°C
Storage temp	-25°C to 65°C
Protection class	II (IEC 60950-1: 2005)
Connection cable	3-wire 1,5 m for MVT203/203S and MVT403/403S
	5-wire 1,5 m for MVT503/503S (CEI20-22/II)
Protection degree	IP43 (CEI EN 60529: 1997)
Weight	0,250 kg
Feedback signal (for MVT503/503S)	2-10 V (2 V fully retracted in direct action or 2 V fully extended in reverse action)
Reference Directives and Standards	EMC 2014/30/UE according to EN 61326-1: 2013 LVD 2014/35/UE according to EN 61010-1: 2010 for MVT2XX

The performances stated in this sheet can be modified without any prior notice.

## ACCESSORIES

**AG74-03** 2-3TGB. B iSMA CONTROLLI valves adaptor  
(N.B. to be used in replacing of the spindle extension provided with the valves).

In case of use of non iSMA CONTROLLI valves please contact technical office for proper adaptor.

## INSTALLATION AND ASSEMBLING

### Models MVT203S - MVT403S - MVT503S

Before assembling the valve and the actuator, check that the set-screw is up. If not, remember that, to mount the actuator on the valve in the right position, you have to overcome the spring strength of the valve itself. Screw in the ring nut M30x1,5 firmly on the valve thread.

### Models MVT203 - MVT403 - MVT503

Mount the actuator on the valve screwing in the ring nut M3x1,5 without locking it; using the manual override make the set-screw go down until to align the actuator spindle slot with the locknut (A), secure with the bolt (B) through not threaded hole in locknut (B). Direct the actuator in the desired position and lock the ring nut M30x1,5.

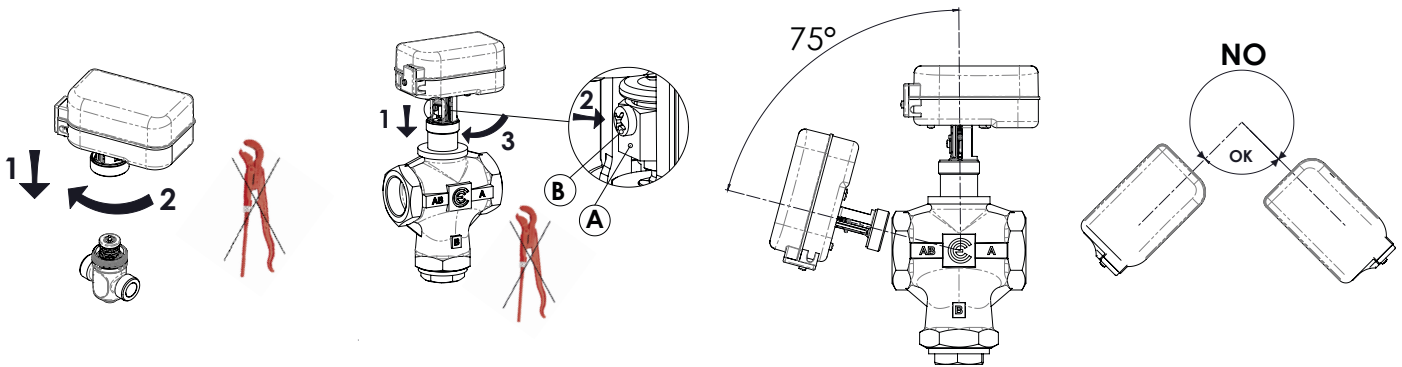

## WIRING DIAGRAMS

### MVT 3-point

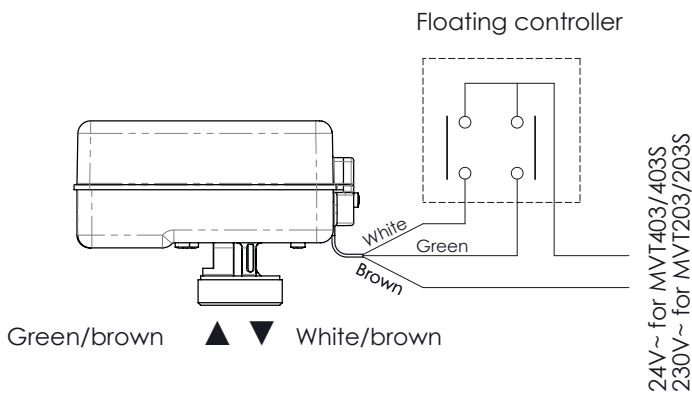

### MVT Proportional

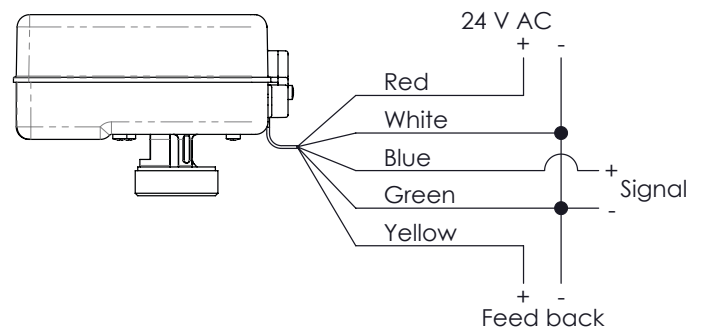

### ON/OFF Connection with External Relay

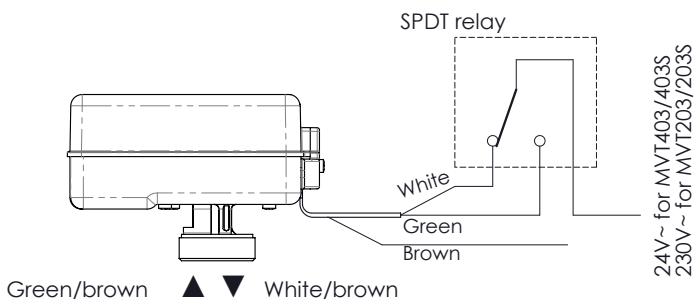

### Replacement of the Old Proportional MVT56/57

Connect together the white and the green cable; then connect the white cable of the new actuator in place of the white cable of MVT56/57, the new blue cable in place of the old green cable and the new red cable in place of the old brown cable..

If you need you can make use of the feedback signal, not available on the old models of actuator.

Do not make electrical connection or changing operation in case actuators are powered.

## Replacement of 3-point ON/OFF MVT28/44

**ATTENTION!** In the 3-point ON/OFF MVT28/44 actuators to be replaced, the common wire is white, while in the new actuators it is BROWN (look at the scheme on the previous page).

## OPERATION

MVT is an electrical bidirectional actuator. The valve stem is activated through a synchronous motor and a gear train optimised in order to have high performances and minimal noise ejections. The actuator is equipped with a movement of limit force which is able to stop the power supply when the force of 300N is reached. If configured as auto calibration stroke, the software of the proportional models enables the stroke calibration, so it can be used on any valve, as long as it respects the maximum stroke limit allowed (look at the above table).

Moreover proportional models are equipped with 3 LEDs whose operation is explained in the table at page 4.

### “MAX STROKE LIMIT” Function (only for MVT503x Models)

In case of powering the actuator not assembled to the valve, “Max Stroke Limit” function is activated to prevent the escape of the screwjack.

- At startup, the actuator is initialized in the UP position (red-green-yellow LED ON).
- If is controlled downward by control signal, when the maximum stroke is exceeded, it will automatically be repositioned UP.

This operation is performed 3 times, then the actuator enters in block mode (yellow LED ON, others OFF).

To reset it, the actuator must be powered down and powered up again.

## POSSIBLE CONNECTIONS AND MATCHES

MVT203S, MVT403S, MVT503S are used with CONTROLI valves VSBT.-VMBT., V.XT, 2TGA..B and with fixed stroke pressure independent valves VSXT..PBP.

MVT203S and MVT403S can be used also for LIBRA series (for modulating control MVT503SB can be used).

Model MVT203, MVT403 and MVT503 are used with valves VSB.T-VMB.T and 2-3TGB.B series.

Models MVT203/203S and MVT403/403S can be connected to any controller with 3 point control signal which has the same power supply characteristics of the actuator as indicated in the paragraph “Technical Characteristics”.

Models MVT503/503S are proportional and they can operate in the ranges 0-10 V DC, 2-10 V DC, 0-5 V DC, 6-10 V DC, 4-20 mA.

## MANUFACTURING CHARACTERISTICS

The actuator housing is made of a polymeric fireproof material; a metal ring M30x1,5 is dedicated to the assembling with the valve. The actuator is equipped with a cable for electric connection.

## SAFETY PRESCRIPTIONS

- Install on the power supply line a protecting device to avoid short circuits (fuse or magneto-thermic) according to the specifications in force;
- in case of accidental removal of the cover and/or of the connector cover, make sure that power is disconnected before working on the actuator or near it;
- the products are maintenance free.

## OPTIONS

**PS107** actuator with M28x1,5 modified ring nut.

## RANGE SELECTION (ONLY MVT503/503S MODELS)

The actuator is supplied prearranged for 0-10 V control signal and direct action; to modify this setting, follow these instructions:

- Remove the cap and the connector (look at the following picture):

For manual override use allen key of 3 mm.

- Change the DIP switches as indicated in the following scheme:

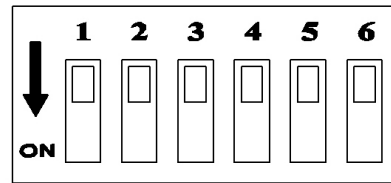
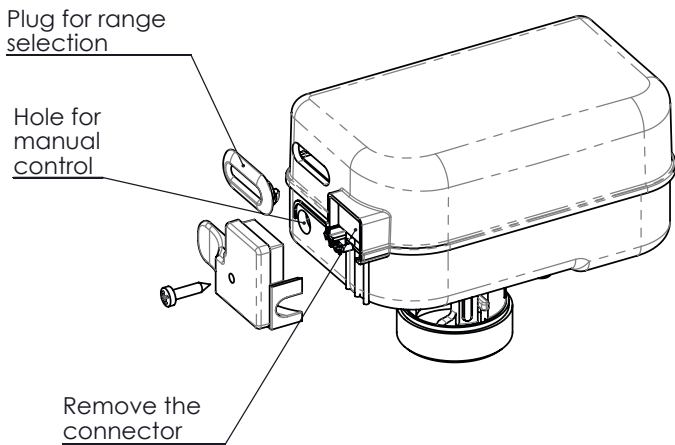

DIP 1	ON = INV action / stroke	OFF = DIR action / stroke
DIP 2	ON = 2-10 / 6-10	OFF = 0-10 / 0-5
DIP 3	ON = Range SEQ	OFF = Range NORM
DIP 4	ON = fixed stroke	OFF = auto calibr. stroke
DIP 5	ON = 4-20 mA	OFF = voltage range
DIP 6	ON = Learning / stroke	OFF = Running / stroke

The actuator can be coupled with push/pull valves VMB.T, VSB.T (with MVTx03) and VX.T (with MVTx03S) using auto calibration stroke; or to valves with spring return as VSX..PB and VSXT..PB or similar (with MVTx03S) using fixed stroke. Actuators with fixed stroke (DIP 4 ON) have only reverse action.

Through DIP 4 you can choose (on the basis of the coupled valve) if the stroke must be fixed or automatically calibrated. In case of fixed stroke (DIP 4 ON) the learning function (DIP 6) and the setting of direct/reverse action (DIP 1) change their meaning: DIP 1 and 6 will be used to choose the fixed stroke value (look at the table).

### Automatic Stroke Range Selection

DIP 1	DIP 6	VALVES STROKE
OFF	OFF	5 mm
OFF	ON	5,5 mm
ON	OFF	2,5 mm
ON	ON	3,5 mm

### Direct Reverse Action

Through DIP1 is possible to set direct or reverse action. In direct action without control signal the actuator is fully retracted with feedback set to 2V. With reverse action the actuator is fully extended and the feedback without control signal is 2 V in this position.

Through DIP 2,3 and 5 it is possible to set 5 different input ranges. If DIP 5 is ON, the input range is set at 4-20 mA and DIP 2 and 3 have no meaning. If DIP 5 is OFF, the possible ranges are: 0-10/2-10 if DIP 3 is OFF and 0-5/6-10 if DIP 3 is ON.

### Automatic Stroke Calibration (Valid Only for DIP n. 4 in OFF)

This function helps to calibrate the maximum valve time stroke, so that the actuator can place the valve correctly following the control signal. If the actuator is powered on, this action can be repeated any time DIP 6 goes from OFF to ON and DIP 4 is OFF. During normal operation, it is possible to choose the position of DIP 6: at each start up the stroke calibration will be carried out if DIP 6 is ON; it will be maintained the previous stroke if DIP 6 is OFF.

### Initial Positioning

It will be carried out every time the actuator will be powered on and the stroke calibration occurs. This procedure allows the actuator to start from a defined position and then follow the control signal. That position depends on the selection of DIP 1 (DIP 4 in OFF). In case the DIP 4 is ON, the initial position means fully extended.

### Retry Function

If an unexpected stop during the stroke occurs, this function has the aim to make it disappear. The actuator will be driven in the opposite direction and then it will try again to reach the position.

### Feedback Output

The actuator is equipped with a proper output to transmit the feedback signal relating to the supposed actuator position. This signal can vary from 2 to 10 V.

During the "automatic stroke calibration" and "Initial positioning" function it is fixed at 2 V.

### LEDS OPERATION

LED	CALIBRATION PHASE	INITIAL POSITIONING	UP POSITIONING	END STROKE UP	DOWN POSITIONING	END STROKE DOWN	ACTUATOR STOP	UNEXPECTED STALL	LOW SUPPLY VOLTAGE	ACTUATOR OFF OR UNDER RESET (SUPPLY VOLTAGE LOW)	MAX STROKE LIMIT PHASE
RED	ALTERNATING 5Hz	ALTERNATING 1Hz	OFF	OFF	BLINKING 1Hz	ON	OFF	SIMULTANEOUS 5Hz	OFF	OFF	ON
GREEN			BLINKING 1Hz	ON	OFF	OFF	OFF		OFF	ON	
YELLOW	ON	ON	ON	ON	ON	ON	ON	ON	BLINKING 1Hz	OFF	ON

