

Smart Balancing Control Valve

VALVE INSTALLATION

Hydraulic Connections:

Follow the fluid directions as shown in the diagram below.

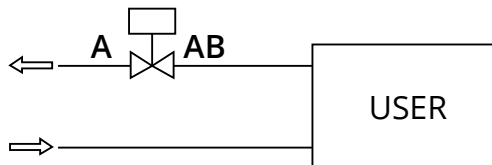

Before installing the valve, make sure the pipes are clean and free from weld slag in order not to damage the internal parts of the valve itself.

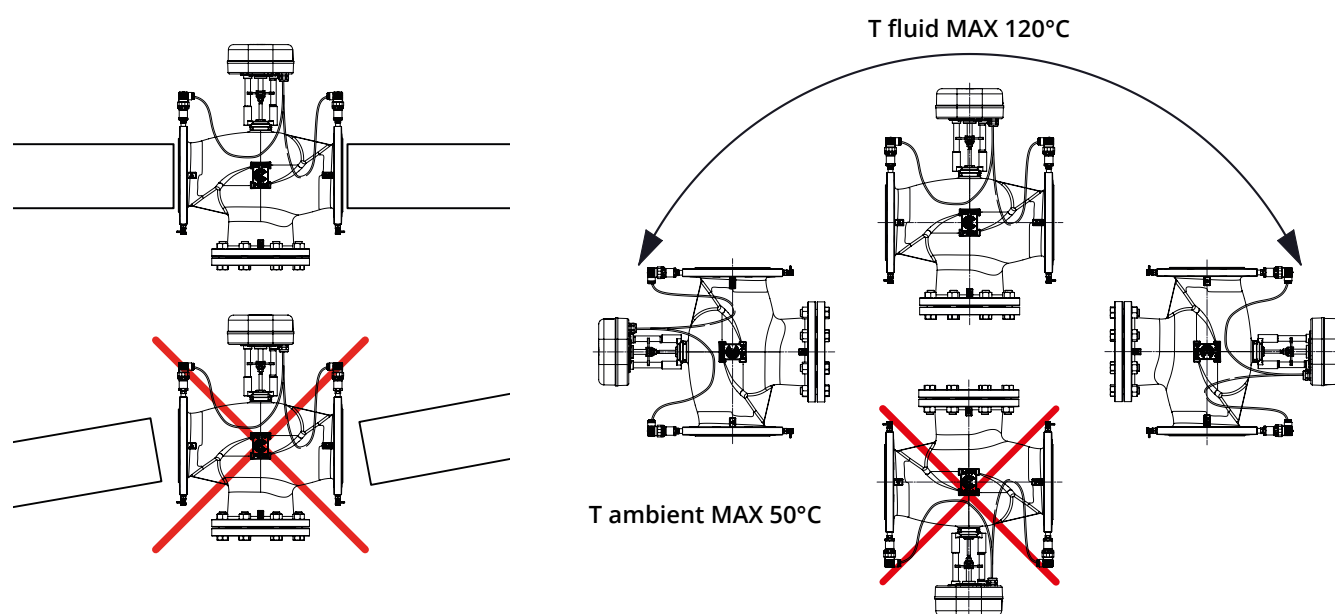

Before the valve start-up, check if the flow correspond to the indication printed on the valve body.

The valve has the following specification according to stem position:

- Stem down = fluid passing
- Stem up = fluid intercepted

OPERATING CONDITIONS

Temperature, nominal pressure and differential pressure on the valve must be within the values specified in data sheets EBV_DBL603en.

PIPE FLUSHING

An anomalous valve leakage is caused, in almost all cases, by weld slag or foreign bodies entrapped between the valve seat and the plug, often causing damages.

To prevent such inconveniences, it is advisable to use filters upstream of the valve.

Moreover, the pipelines must be properly washed positioning the valve stem at half stroke; this operation must be performed before start-up and after a prolonged shutdown of the system.

VALVE MAINTENANCE

Valves are equipped with a stuffing box with a double Oring and, therefore, they do not require any particular maintenance. In case of irregular leakage, O-Rings and stem packing have to be replaced.

The performances stated in this sheet can be modified without any prior notice.

PRESSURE SENSORS INSTALLATION

Make sure that the fluid is not present in the system and remove the closing caps on the valve flanges. Insert the MF extension and pressure transducers as indicated in the figure below.

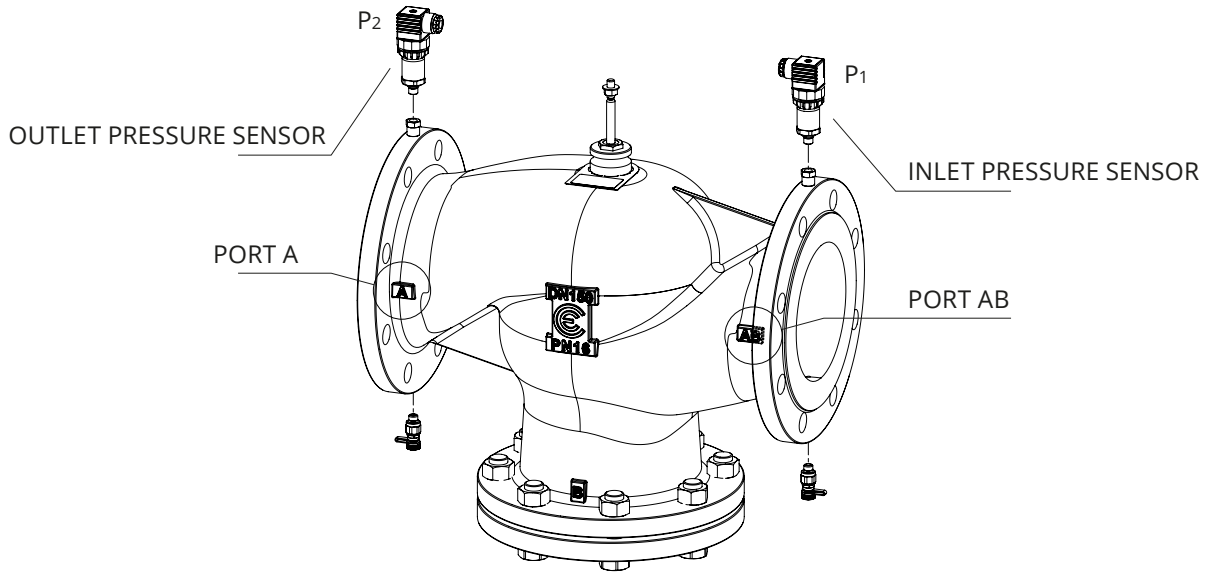

ACTUATOR INSTALLATION

The actuators must not be installed in explosive atmosphere and must not be subjected to steam jets of water or dripping. Leave a space above the actuator sufficient to allow the uncoupling of the actuator from the valve body for any maintenance, at least 10-15 cm.

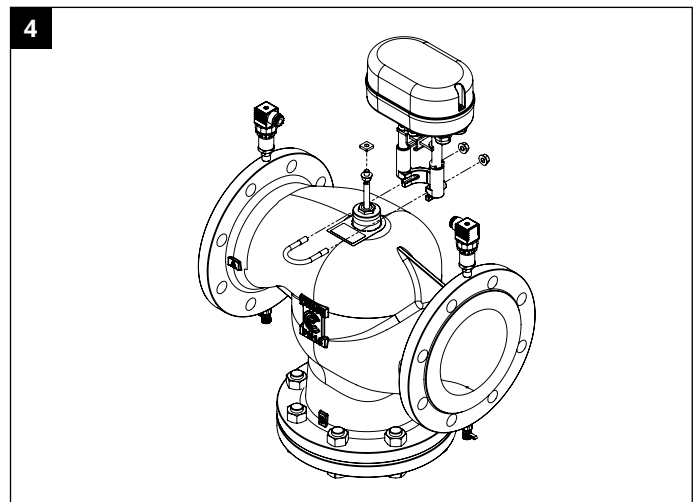
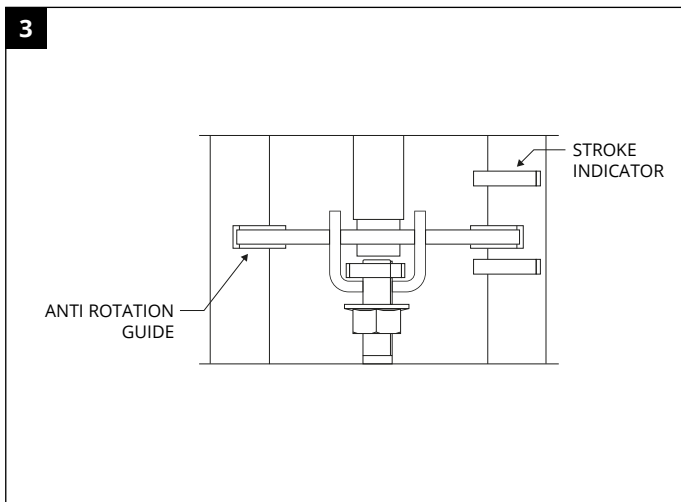
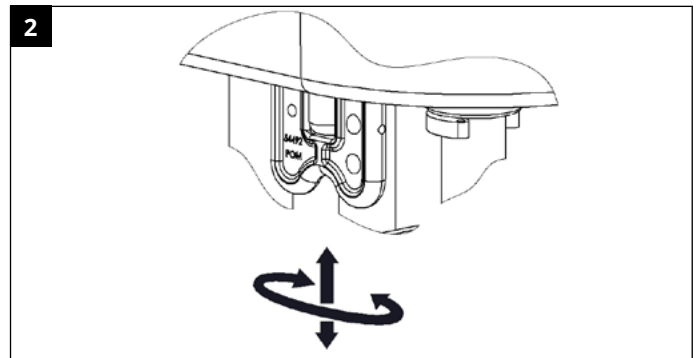
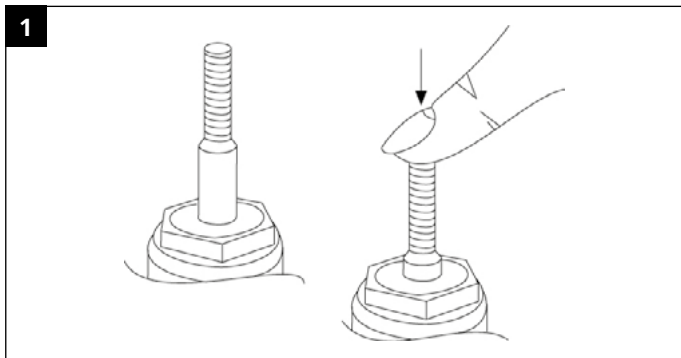

WIRING CONNECTION

Remove the cover screw with a screwdriver and then remove the cover as shown in the picture beside.



24 V models (EBVxx-024-xxx)

The actuator is equipped with 3 removable terminal block:

- a removable 8-poles terminal block (T1) with power supply, analog and digital command signal and feedback signal; each terminal pole is clearly marked and the same label is shown on the electronic board. Before turning on the actuator, make sure that the terminal block is correctly connected to the board and that the label on the terminals and board match;
- a removable 6-poles terminal block (T2) dedicated to the RS485 bus connection (Modbus);
- a removable 6-poles terminal block (T3) dedicated to the connections of the temperature sensors (only 4 poles are used).

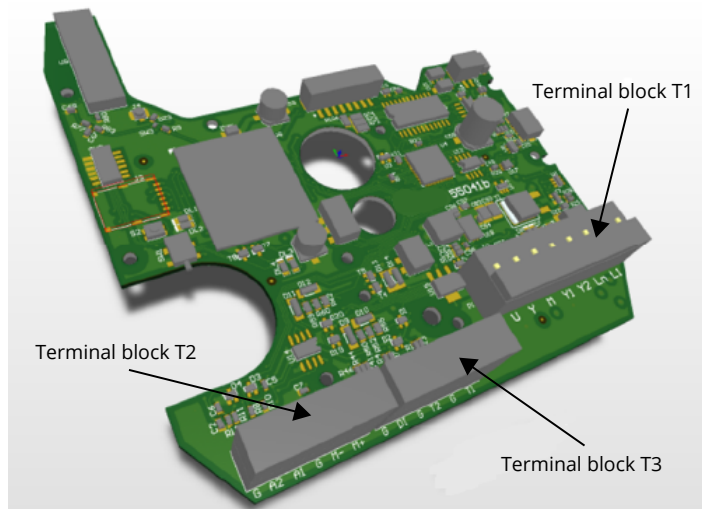

230 V models (EBVxx-230-xxx)

The actuator is equipped with 4 removable terminal block:

- a not removable 2 poles terminal block for main power supply;
- a removable 6-poles terminal block (T1) with power supply, analog command signal and feedback signal; each terminal pole is clearly marked and the same label is shown on the electronic board. Before turning on the actuator, make sure that the terminal block is correctly connected to the board and that the label on the terminals and board match;
- a removable 6-poles terminal block (T2) dedicated to the RS485 bus connection (Modbus RTU or BACnet MS/TP) - (only 3 poles are used);
- a removable 6-poles terminal block (T3) dedicated to the connections of the temperature sensors (only 4 poles are used).

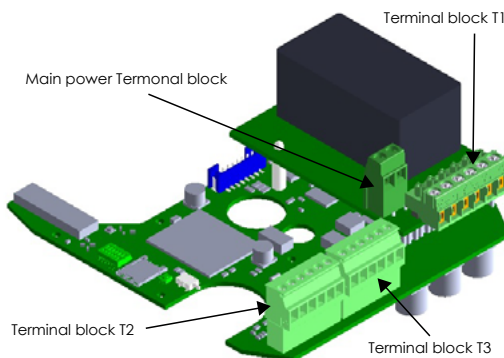

TERMINAL BLOCK T1

Terminal block T1 (24 V)

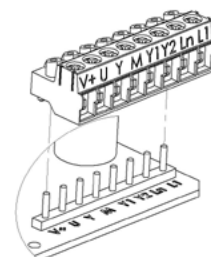
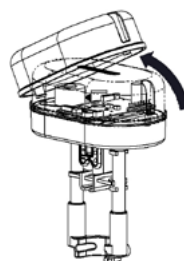
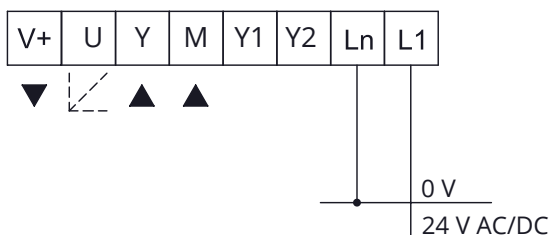

Label	Description	Function	Cable type	Max wire length
L1	24 V AC/DC	Power supply	AWG 16 (min 1 mm ² - max 1,5 mm ²)	75 m
Ln	0 V			
Y	0-10 V DC	Modulating control input	AWG 20 (min 0,5 mm ² - max 1,5 mm ²)	200 m
M	0 V (common)			
Y1	Not used			
Y2				
V+	16 V DC	Power supply for pressure sensors	AWG 20 (min 0,5 mm ² - max 1,5 mm ²)	200 m
M	0 V (common)			
U	2-10 V DC	Feedback output signal	AWG 20 (min 0,5 mm ² - max 1,5 mm ²)	200 m
M	0 V (common)			

Terminal block T1 (230 V)

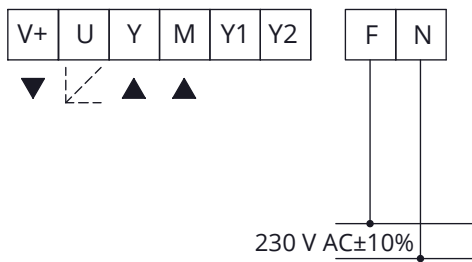

Label	Description	Function	Cable type	Max wire length
F	230 V AC	Power supply	AWG 16 (min 1 mm ² - max 1,5 mm ²)	75 m
N				
Y	0-10 V DC	Modulating control input	AWG 20 (min 0,5 mm ² - max 1,5 mm ²)	200 m
M	0 V (common)			
Y1	Not used			
Y2				
V+	16 V DC	Current output max 25 mA	AWG 20 (min 0,5 mm ² - max 1,5 mm ²)	200 m
M	0 V (common)			
U	2-10 V DC	Feedback output signal	AWG 20 (min 0,5 mm ² - max 1,5 mm ²)	200 m
M	0 V (common)			

TERMINAL BLOCK T2

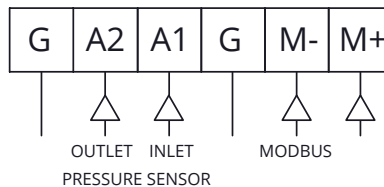

Label	Description	Function	Cable type	Max wire length
M+	Tx	Modbus connection	Belden 8762	See chapter Modbus – RS485
M-	Rx			
G	Shield			

A1	0-10 V from pressure sensor (inlet pressure)	ΔP reading	Three-core cable supplied	75 cm
A2	0-10 V from pressure sensor (outlet pressure)			
G	0 V (Common)	Pressure sensor common		75 cm

TERMINAL BLOCK T3

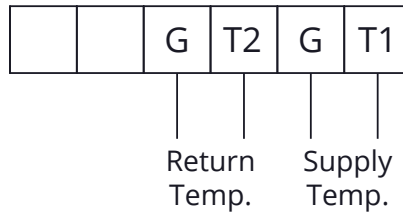

Label	Description	Function	Max wire length
T1	Supply temp. sensor	ΔT limit function, energy monitoring and power control function	3 m
G	Common		
T2	Return temp. sensor		
G	Common		

PRESSURE TRANSDUCERS CONNECTION

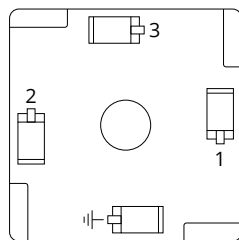

DIN CONNECTOR
EN175301-803-A

Label	Description	Function	Cable type	Max wire length
1	Power supply	Differential Pressure Reading	Three poles wire (supplied)	75 cm
2	0-10 V Signal			
3	Common			

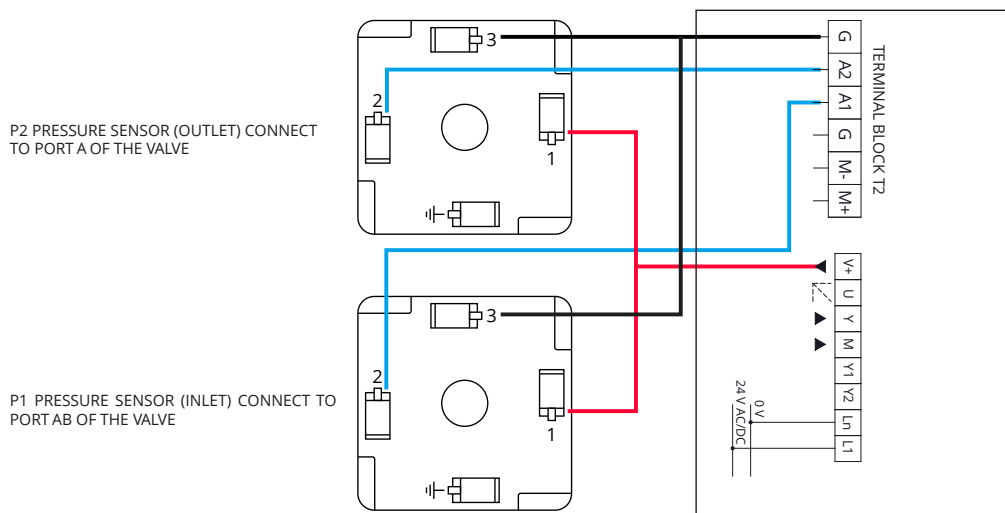

Modbus Control

24 V AC/DC

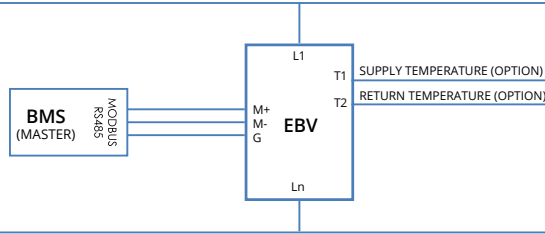

0 V

230 V AC

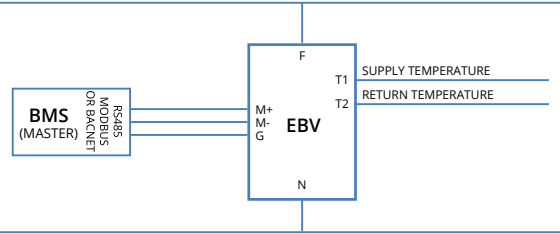

0 V

Modulating Control & Modbus Supervisory

24 V AC/DC

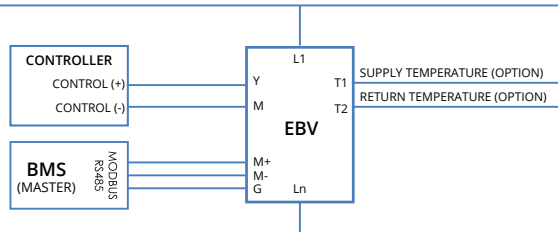

0 V

230 V AC

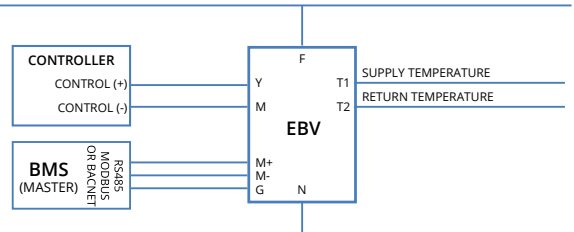

0 V

Note: To avoid damages to electronic components caused by the PCB bending, do not press too much while fixing the terminal block.

Each pole of the terminal blocks is clearly marked and the same label is on the electronic board.

Before turning on the actuator make sure that the terminal blocks are correctly connected to the board and that the labels on the terminals and board match.

CABLE GLAND

The actuator is supplied with 2 cable glands with punched membranes for safe and tidy wiring.



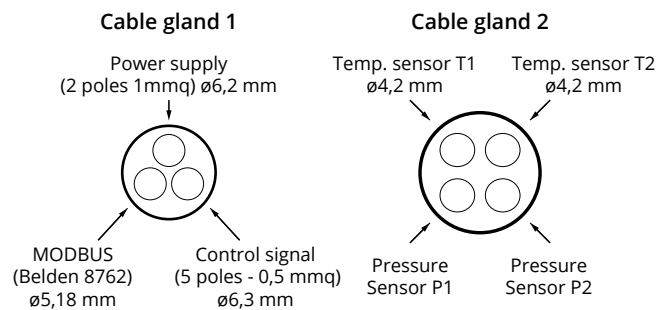

- Cable gland 1 for 3 cables: 2-wire cable for power supply; 5-wire cable for control and feedback signals and 3-wire cable for Modbus;
- Cable gland 2 for 4 cables: 2 cables with 2 wires for temperature sensors (if present) and 2 cables with 3 wires for pressure transmitters.

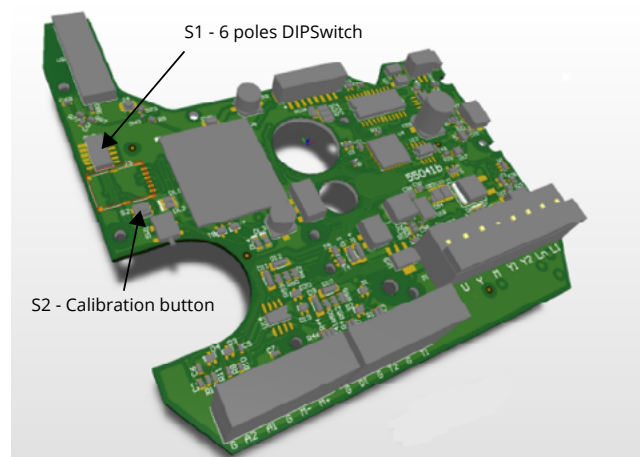
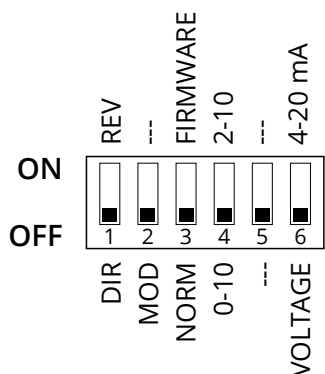

DIPSWITCH SETTING

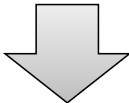
DEFAULT SETTINGS

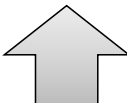

DIP switch	OFF	ON
1	Direct action  U = feedback  U = 2V  U = 10V	Reverse action  U = feedback  U = 10V  U = 2V
2	Modulating Control (MOD) (Input between Y [+] and M [-])	Not used
3	Normal operating	Firmware update
4	Modulating Control 0-10Vdc (DIP n. 2 OFF only)	Modulating Control 2-10Vdc (DIP n. 2 OFF only)
5	Not used	Not used
6	Voltage Input Signal (input between Y [+] and M [-])	Current Input Signal 4-20mA (input between Y [+] and M [-])

Emergency return jumper (EBVxx-xxx-1xx)

Jumper for emergency return position selection (open jumper - totally retracted joint; closed jumper - totally extended joint)

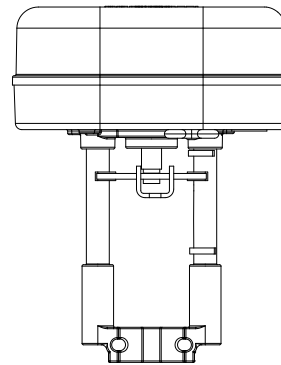
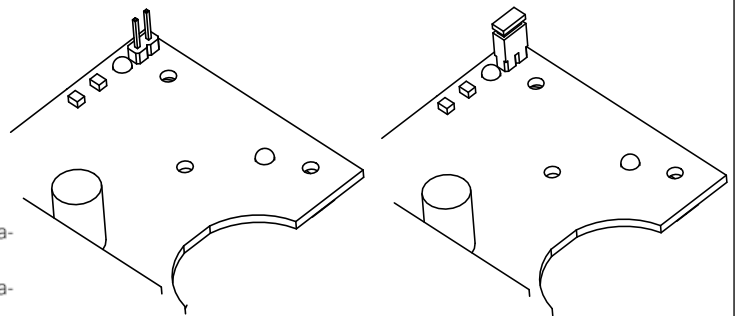
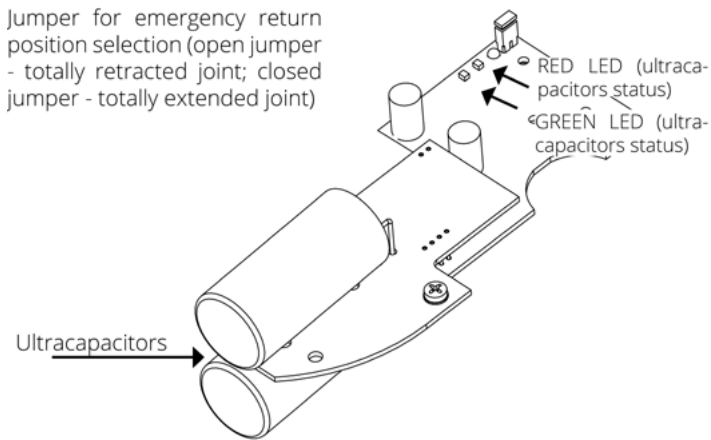

Open jumper retracted joint

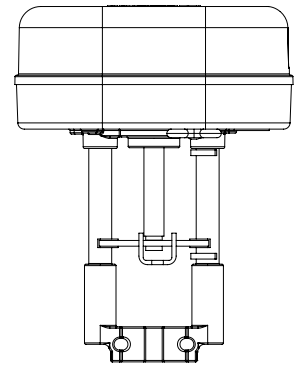

Closed jumper extended joint

DIAGNOSTIC - ALARM FUNCTIONS

N°	Error type	Actuator status	Actuator behavior	LEDs notification	Possible anomaly	Restore procedure
1	Stroke less than 5 mm	Calibration / first installation	The actuator returns to its initial position and does not respond to the command. The actuator keeps the previous stroke or the default stroke	RED ON	Valve with stroke less than 5 mm	Remove power and re-power again
	Stroke greater than 60 mm	Calibration / first installation	The actuator leaves the maximum range of 60mm and moves to the new extreme. Once the new stroke limit is reached, it returns to the initial position signaling an anomaly. The actuator does not learn the new stroke.	RED fast blinking + GREEN ON	Valve with stroke greater than 60 mm or incorrect coupling	Remove power and re-power again
2	Unexpected collision within the stroke	Normal operation	The actuator checks the stall condition 5 times. At the end of the attempts it signals an anomaly. The actuator does NOT learn the new stroke, but after 60s repeats the attempts to check the blocking conditions.	RED fast blinking	Valve blocked	Reverse the control signal
3	Stroke greater than expected	Normal operation	The actuator moves to the new crash position with low speed signaling an anomaly. The actuator does NOT learn the new stroke.	RED fast blinking	Damaged valve or incorrect coupling	Reverse the control signal
4	Low supply voltage	Normal operation	The actuator continues to operate but performance is not guaranteed. If the low voltage events persist (events greater than 10), the actuator stops working.	RED blinking alternately fast (5sec) and slow (5sec) + GREEN ON	1. Wrong sizing of transformer	Check and restore power
					2. Unstable power supply	
5	High supply voltage	Normal operation	The actuator continues to operate but performance is not guaranteed. If the high voltage events persist (events greater than 10), the actuator stops working.	RED slow blinking	1. Wrong sizing of transformer	Check and restore power
					2. Unstable power supply	
6	Temperature sensors error	Normal operation	Temperature or ΔT regulation loops not working.	RED blinking alternately fast (5sec) and slow (5sec) + GREEN ON	1. Incorrect temperature probe connection	Check the connection and the condition of the temperature sensor
					2. Temperature probes damaged	
					3. Temperature detected outside the range of use	
7	Pressure sensors error	Normal operation	Pressure or ΔP regulation Loops not working		Pressure detected outside the range of use or probes damaged	

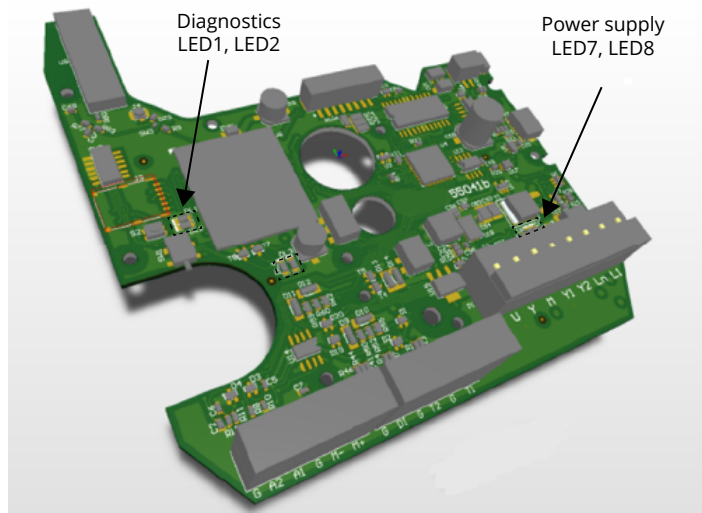

N°	LED 1 and LED 2	Actuator status
1	FIXED GREEN	Actuator has arrived at the extreme end of the calibration stroke
2	GREEN SLOW BLINKING	Actuator has arrived or is moving towards an intermediate point of the calibration stroke
3	RED and GREEN BLINKING ALTERNATIVELY	Actuator is calibrating the stroke or performing the initial positioning
4	RED and GREEN FIXED	Manual control activated, the actuator ignores the control signal. WARNING! The board is powered

N°	LED 7 (RED) and LED 8 (RED)	Actuator status
1	LED 7 RED ON; LED 8 RED ON	Stable power supply of the actuator
2	LED 7 RED ON; LED 8 OFF	Unstable actuator power supply; possible hardware problem

Supercap for emergency return models only (EBVxxx-xxx-1xx)

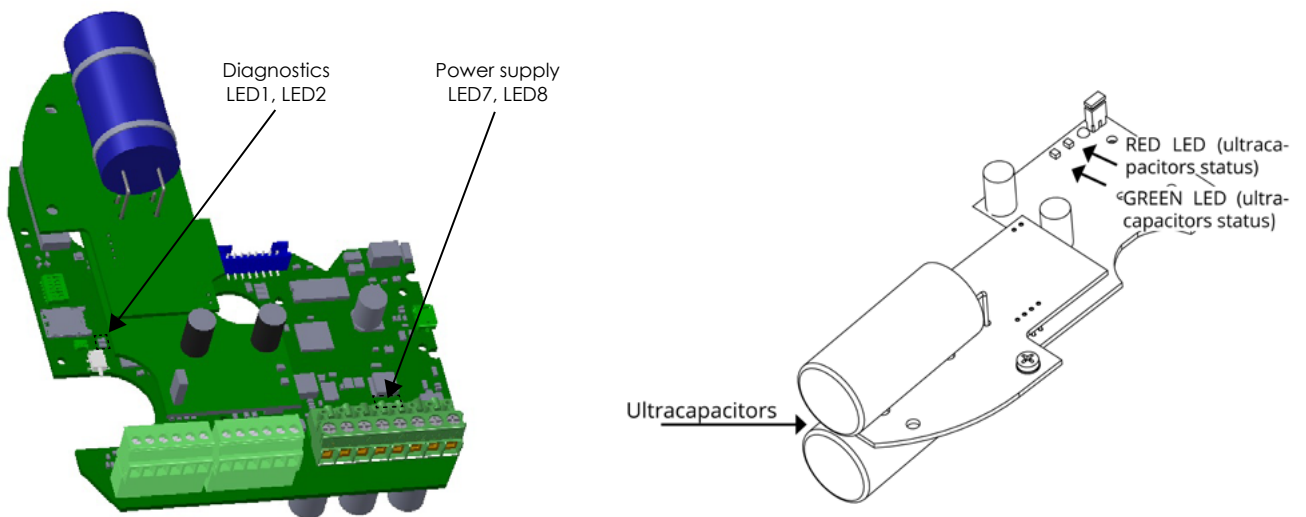

LED	ULTRACAPACITORS STATUS
GREEN	Ultracapacitor charged
RED	Ultracapacitor discharging
OFF	Ultracapacitor totally discharged

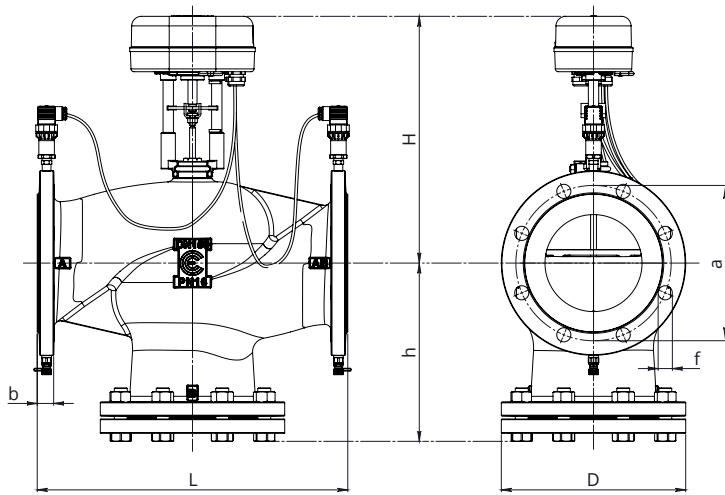

Temperature sensor wells

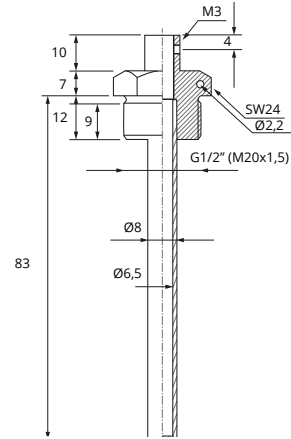

Mod.	DN	L	H	h	D	b	a	f	Holes	Weight [kg]
EBV	65	290	320	175	185	20	145	18	4	18
	80	310	330	186	200	22	160	18	8	28
	100	350	341	206	220	24	180	18	8	32
	125	400	364	255	250	26	210	22	8	45
	150	480	382	275	285	26	240	25	8	60

Temperature sensor

