

## Valve Actuators with Emergency Return Device

MODEL	FORCE [N]	POWER SUPPLY	DESCRIPTION
MVH56EA	700	24V AC/DC	Modulating/floating with emergency return device with retracted joint (valve stem up)
MVH56EC	700	24V AC/DC	Modulating/floating with emergency return device with extended joint (valve stem down)

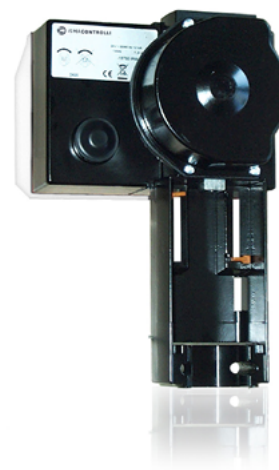

### APPLICATION AND USE

MVH56Ex is a flexible electro-mechanical actuator for the control of two and three way globe valves in:

- Heating and Cooling systems
- Air handling units
- District Heating plants
- Industrial Temperature Control systems.

MVH56Ex can be controlled either by a proportional (modulating) signal or by an increase/decrease (floating) signal.

It is easy to mount and connect the actuator. Direct mounting is possible to any iSMA CONTROLLI flanged valve. Linkage kits are available for iSMA CONTROLLI threaded valves as well as for valves of other manufacturers (contact our technical Dept.). The actuator has a fine resolution (500 steps on the full stroke range) for exacting fluid control and it is able to self-calibrate on a different stroke without the need of any user action (this function is selectable on the field via DIP switch).

MVH56Ex has intelligent behaviour and alarm functionality in case of unexpected operation; feedback of alarms to the user is provided by two LEDs (GREEN and RED) on the control board.

N.B.: Do not use the actuator if not coupled with the valve.

### TECHNICAL CHARACTERISTICS

DESCRIPTION		MVH56EA	MVH56EC
Supply voltage L1 Ln		AC: 24 V AC $\pm$ 20% 50-60 Hz DC:22-30 V DC (Reference Ln)	
Power consumption (running)		13 VA/6 W	
Power consumption (Holding)		8 VA/4 W	
Running and emergency return time (empty)		~ 1 sec/mm	
Running and emergency return time (loaded)		~ 2 sec/mm	
Running time	Modulating	15 s (for valves with stroke from 5 to 15 mm)	
		25 s (for valves with stroke from 15 to 25 mm)	
		35 s (for valves with stroke from 25 to 40 mm)	
		50 s (for valves with stroke from 40 to 50 mm)	
	Floating	60 s	
Transformer Size [VA]		50	60
Stroke		5-50 mm	
Force [N]		700	700
Duty cycle		Max. 50%/60 minutes	
Analog input Y M		Voltage 0-10 V - impedance > 100 k $\Omega$ (range: 0-10 2-10 0-5/2-6 5-10/6-10) 500 $\Omega$ (range 4-20 mA)	

The performances stated in this sheet can be modified without any prior notice.

DESCRIPTION	MVH56EA	MVH56EC
Digital inputs Y1-Y2	Connection to L1 or Ln when powered in AC Connection to Ln only when powered in DC	
Output V+	Voltage 16 V DC $\pm$ 0,5 V	
	Max. load 25 mA,	
Output U	Voltage 2-10 V DC (0-100%)	
	Max. load 2 mA	
Cable glands	Plastic punchable, replaceable by PG13,5 compression glands	
Type of movement	Linear	
Ambient temperature	Operation -10°C to 60°C Storage -20°C to 60°C	
Ambient Humidity	Max. 90% RH	
Protection degree	IP55 DIN40050 (IEC 529) for highly polluted environments according to IEC 730-1 (93)/6,5,3	
Insulation class		
Standard	Emission/Immunity EMC 2014/30/UE according to EN 61326-1:2013 standard	
Weight [kg]	4	

## OPERATION

The actuator translates the control signal (modulating or 3 point floating) from the controller into a valve position. A modern brushless DC motor in the actuator drive a gear train and a worm gear – screw jack mechanism convert the motor revolutions into accurate and repeatable linear movements.

### Control Signal

MVH56Ex can be controlled by two main control types.

- 3 point floating ;
- Modulating (or proportional) signal with filed selectable range (e.g., 0-10 V DC, 2-10 V DC, 0-5/2-6 V DC, 5-10/6-10 V DC e 4-20 mA.)

### Feedback Signal

The actuator utilizes a 2-10 V position feedback (look at DIP n. 1 settings).

### Calibration

The actuator has both Auto and Manual Stroke Calibration, DIP n. 7. In factory delivery the auto stroke calibration is enabled; manual calibration is not necessary unless maintenance is required on the valve or certain alarm functions are desired.

They are provided with a spring device which, in case of power loss, makes the actuator return to the rest position.

## MANUFACTURING CHARACTERISTICS

The actuator consists in a die-cast aluminium housing, which includes the mounting bracket for connection to valve body. Reduction gears supported by ball bearings. Movement is transmitted to a rack-and-pinion mechanism connected to the valve stem through a suitable joint.

Internal electronic card with easily accessible terminals for electrical connections. Spring return device consisting of a fl at spring placed outside the main shaft.

### End Point Auxiliary Switches (accessory DMVH)

End point switches change over when the valve is fully open or closed. They are free contacts with 24Vac max voltage on terminals. End point switches can be utilized to indicate valve stroke end positions and for relay control of additional plant equipment.

When the actuators are controlled individually or in sequence, it is possible to use the end switches to toggle when the valve is fully open or fully closed. The auxiliary switch position according to control signal (Y) is shown in the next table.

CONTROL SIGNAL (Y)	RELAY KC1	RELAY KC2
0-0,5 V DC	KC1 to K2	KC2 to K3
0,5-9,5 V DC	KC1 to K1	KC2 to K3
9,5-10 V DC	KC1 to K1	KC2 to K4

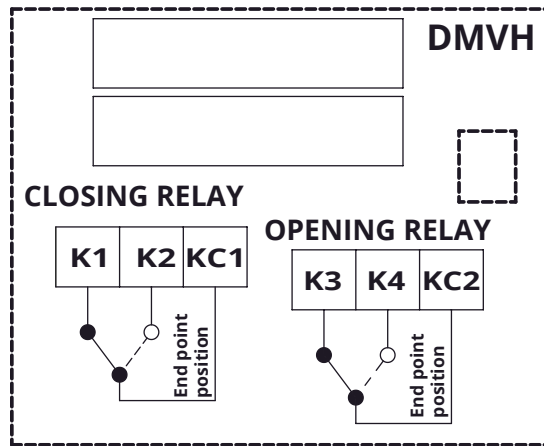

### Diagnostic

The actuator is provided with a self diagnostic algorithm able to detect faulty conditions:

- stroke out of range 5-50 mm;
- unexpected stall condition (e.g., valve stuck);
- missing expected stall condition (e.g., link loose);
- voltage supply out of range.

These faulty conditions are signaled via the GREEN and RED LED on the electronic board blinking accordingly (see "Diagnostic – Alarm Function Table").

### ASSEMBLING

The actuator can be mounted in the positions shown picture below:

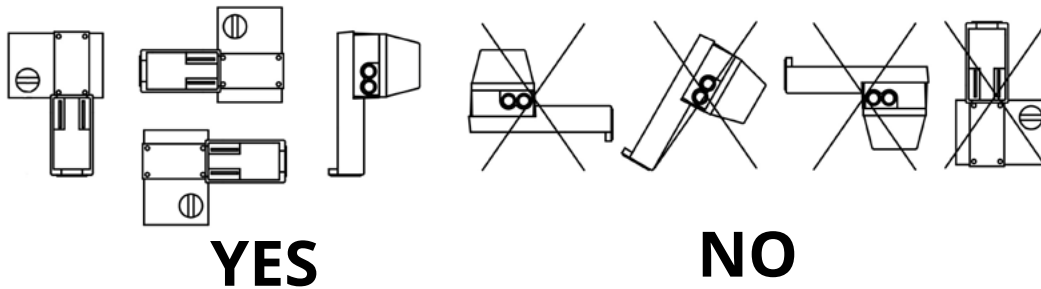

It is advisable to use the motorized valve with MVHT spacer, in order to reduce the actuator working temperature in case of fluids at high temperatures (approximately > 120°C) in the valve body. For fluids over 160°C avoid mounting the actuator in vertical position on the valve so as to avoid the direct exposure to heat sources. For further information look at mounting instructions (MVH56Ex\_DIM262).

### MAINTENANCE

The actuator is maintenance-free.

### ACCESSORIES

2 auxiliary microswitches (SPDT 10 (3) A-250 V~) adjustable on the whole stroke. Microdisconnection type 1B according to IEC 730-1(93)/6.4.3.2. It is possible to place the cams so that the microswitches act according to the required position. Keep in mind that when the lever is on the cam protruding part, the contact is closed between b and c and open between c and a (see figure below).

DMVH

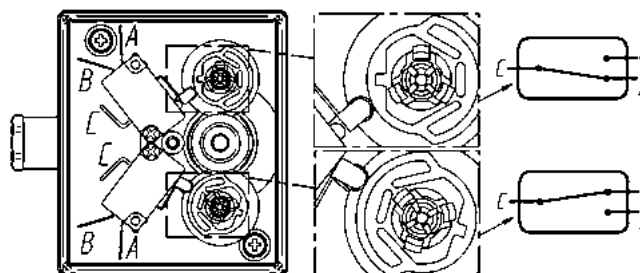

- AG62** Linkage kit for VMB e VSB valves.
  - 248** Stem heater (Suggested when the fluid temperature is lower than -10°C) \*
  - MVHT** Valve body-actuator spacer reducing the actuator direct exposure in case of installation with high-temperature fluids. Dimensions: Ø 120 mm; h = actuator height + 102 mm
  - GMVHAC** Thermal insulation for MVH.A/C actuators \*
- \* It is not possible to install both thermal insulation (Gxxxx) and stem heaters.

## ELECTRICAL CONNECTIONS

Carry out the electrical connections by removing the cover, in compliance with the rules in force.

The actuator is equipped with a 8 poles removable terminal block; the each pole of the plug is clearly marked and the same label are reported on the electric board. Before powering up the actuator make sure the plug is properly connected to the board and the label on the plugs and on the board match.

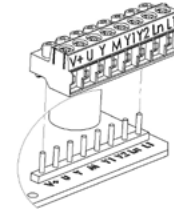

### Terminal block

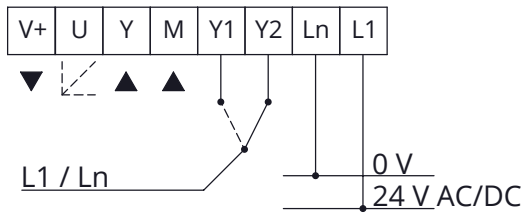

### Matching between MVH56Ex terminal block and other iSMA CONTROLLI actuators

G	G0	MX	G1	X1	VH	VC	Y	MVH56FA
G	G0	MX	G1	X1	VH	VC	Y	MVH56FC
L1	LN	M	V+	Y	Y1	Y2	U	MVH56Ex

LABEL	DESCRIPTION	FUNCTION	CABLE TYPE	MAX. WIRE LENGTH
L1	24 V AC/DC	Power Supply	AWG 16 (min 1mm <sup>2</sup> - max 1.5mm <sup>2</sup> )	75 m
Ln	0 V			
Y	0-10 V DC	Modulating Control Input	AWG 20 (min 0,5mm <sup>2</sup> - max 1.5mm <sup>2</sup> )	200 m
M	0 V (Common)			
Y1	Open	Floating Control Input	AWG 20 (min 0,5mm <sup>2</sup> - max 1.5mm <sup>2</sup> )	200 m
Y2	Close			
V+	16 V DC	Voltage Output max. 25 mA	AWG 20 (min 0,5mm <sup>2</sup> - max 1.5mm <sup>2</sup> )	200 m
M	0 V (Common)			
U	2-10 V DC	Feedback Output Signal	AWG 20 (min 0,5mm <sup>2</sup> - max 1.5mm <sup>2</sup> )	200 m
M	0 V (Common)			

### 3 point floating control (sink connection)

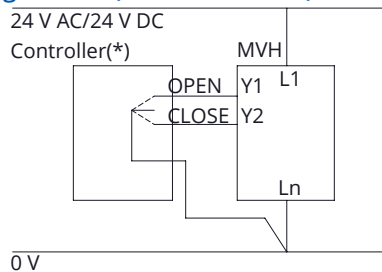

### 3 point floating control (source connection)

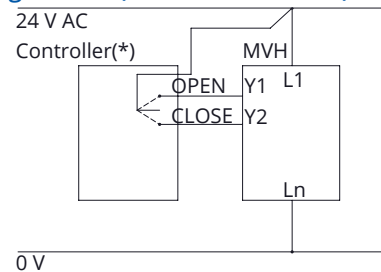

### Modulating control (0-10 V DC)

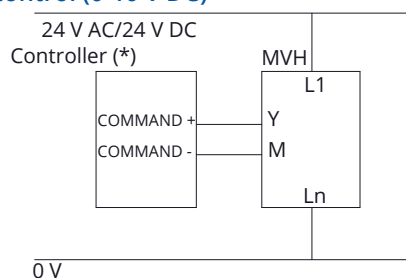

N.B: M and Ln signal are internally connected.  
 (\*) MVH56Ex actuators contain a half-wave rectifier power supply.  
 They must not be powered with transformers that are used to power other devices using not isolated full-wave rectifier power supply.

## DIP SWITCHES SETTINGS

Set the DIP switches according to the tables here below. Power down and power up again the actuator or act on the manual operation handle to be sure that settings will be recognized.

### Factory settings

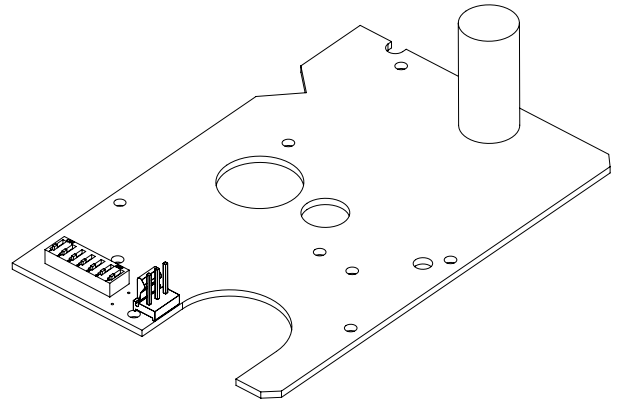
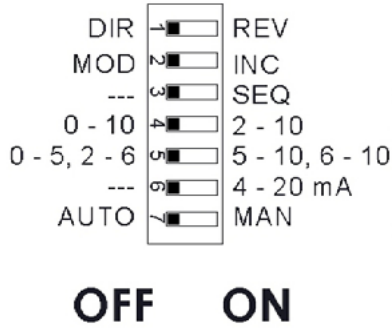

DIP SWITCH		OFF	ON
1	MVH56EA	Direct Action U= feedback   U = 2V U = 10V	Reverse Action U= feedback   U = 10V U = 2V
	MVH56EC	Reverse Action U= feedback   U = 10V U = 2V	Direct Action U= feedback   U = 2V U = 10V
2	MVH56EA	Modulating Control (MOD) (Input between Y [+] and M [-]) 	3 point floating (INC) ( Y1 open , Y2 close connected L1 or Ln if powered in Vacd; if powered in Vdc connected necessarily to Ln ) 
	MVH56EC	Modulating Control (MOD) (Input between Y [+] and M [-]) 	3 point floating (INC) ( Y1 open , Y2 close connected L1 or Ln if powered in Vacd; if powered in Vdc connected necessarily to Ln ) 
3	-	-	Selection of sequence mode, control range defined by SW 5
4	Modulating Control 0-10 V DC (DIP n. 2 OFF only)	-	Modulating Control 2-10Vdc (DIP n. 2 OFF only)
5	Sequence Control 0-5 V DC with DIP n. 4 OFF only Sequence Control 2-6 V DC with DIP n. 4 ON only (DIP n. 3 ON only)	-	Sequence Control 5-10 V DC with DIP n. 4 OFF only Sequence Control 6-10 V DC with DIP n. 4 ON only (DIP n. 3 ON only)
6	Voltage Input Signal (input between Y [+] and M [-])	-	Current Input Signal 4-20 mA (input between Y [+] and M [-]). In this case DIP n. 4 must be set to ON.
7	Automatic Calibration: the actuator updates the stroke range every time an unexpected mechanical stop is detected for at least 10s	-	Manual Calibration: the actuator calibration is started moving the DIP from OFF to ON; if the DIP is left in ON the actuator will never update the calibrated stroke value even when an unexpected endpoint is detected

N°	LED BEHAVIOUR	ERROR	ACTUATOR USE	ACTUATOR BEHAVIOUR		TYPICAL TROUBLE SHOOTING CONDITION	RESET PROCEDURE
				AUTOMATIC CALIBRATION (DIP N. 7 OFF)	MANUAL CALIBRATION (DIP N. 7 ON)		
1	RED ON	valve stroke less than 5mm	Calibration/ first installation	The actuator pushes/pulls 5 times (unexpected stall) trying to remove the possible obstacle. After 5 tries an alarm is signalled (RED LED ON) and the actuator moves to initial position and does not respond to control signal. Stroke value is not updated because out of range	The actuator pushes/pulls 2 times against endpoint during calibration. Alarm is signalled (RED LED ON) and the actuator moves to the initial position and then it does not respond to the control signal	Valve with a stroke length lower than 5mm	Remove power and power up again
2	RED ON	Stroke longer than 50mm	Calibration/ first installation	The actuator exits the 50 mm stroke range and it moves toward the new stroke limit signalling an anomaly (RED LED ON). The actuator does not calibrate the stroke	The actuator pushes/pulls 2 times against endpoint during calibration. Alarm is signalled (RED LED ON) and the actuator moves to the initial position and then it does not respond to the control signal	Valve with a stroke length longer than 50mm	Remove power and power up again
3	RED Quick Blinking + GREEN ON	Unexpected stall within the calibrated stroke range	normal operation	The actuator tries 5 times against the new stall condition and then after 10s the actuator updates the new stroke length; During these 10s RED LED is ON	The actuator tries 5 times against the new stall condition. At the end of the attempts the fault will be signalled (RED LED ON). The actuator does not update the new stroke length, but after 60s makes other attempts to verify the stall condition	Valve stuck	Inverted control signal
4	RED Quick Blinking + GREEN ON	Stroke longer than expected	normal operation	The actuator moves toward the new stall condition with a lower speed; after 10s the actuator updates the new stroke value; During these 10s RED LED is ON	The actuator moves toward the new stall condition with a lower speed; after 10s the actuator does not update the new stroke value	stem connection loose or valve damaged	Inverted control signal
5	RED slow Blinking	Low Power Voltage	normal operation	The actuator is still working but performance cannot be guaranteed	The actuator is still working but performance cannot be guaranteed	1. Wrong transformer size 2. Unstable power	Correct Voltage Power
6	RED slow Blinking	High Power Voltage	normal operation	The actuator is still working but performance cannot be guaranteed	The actuator is still working but performance cannot be guaranteed	1. Wrong transformer size	Correct Voltage Power

## STANDARD LEDs

N°	LED	ACTUATOR STATUS
1	GREEN ON	The actuator arrived at the extreme point of the stroke read
2	GREEN BLINKING	The actuator arrived at the intermediate point of the stroke read
3	RED GREEN BLINKING	The actuator is reading the stroke or it is going to initial position
4	RED GREEN ON	Manual control ON, the actuator ignores the control signal. ATTENTION! The electronic board is electrically supplied

## DIMENSIONS [mm]

